



TECHNISCHE
UNIVERSITÄT
WIEN

Vienna University of Technology

Profitability analysis and business models for shared use of PV systems in multi-apartment buildings

- Case studies for Austria and Germany

Author: Bernadette Fina

Affiliation: Energy Economics Group (EEG)
Technische Universität Wien

1. Motivation and Question

2. Model and Method

→ Model procedure

→ Method:

Optimal dimensioning of PV systems and storages based on a multi-objective optimization approach

3. Results

Profitability analyses, calculated for Austrian and German retail electricity prices in comparison, for ...

→ Individual apartments' load profiles

→ Building considered as total load

4. Business models for communal PV systems in Austria

5. Conclusions

1. Motivation and Question

Motivation:

- Profitability of PV systems has been rising
- Usage of PV electricity so far just for single-family homes
- Legal background in Austria for implementation of PV systems in multi-apartment buildings since July 2017

Question:

- Optimal dimensioning of PV systems and storages for multi-apartment buildings with different objective functions (minimization of annual electricity costs, maximization of self-consumption)
- Economic viability of the shared PV concept
- Development of business models for usage of communal PV systems

2. Model and Method (1/4)

Model procedure – a brief overview

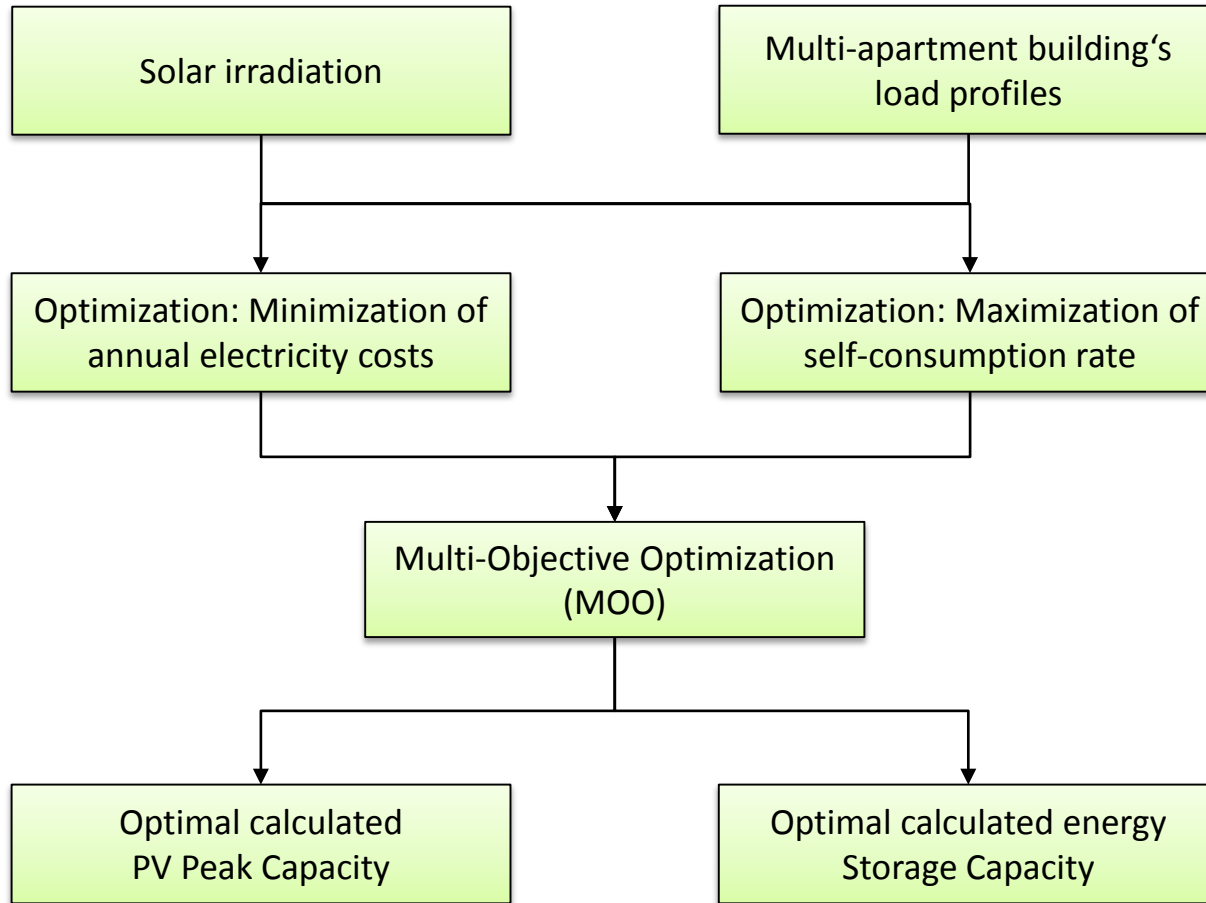

2. Model and Method (2/4)

Optimization: Minimization of annual electricity costs

$$EC_{min} = \min \sum C_{var} + C_{pvPeak} + C_{PV_b} + C_{else} + C_{stor}$$

$$C_{var} = \sum_{t=0}^{t=35040} e_{grid}(t) * c_{var_elec} - e_{pv2grid}(t) * p_{feed_in}$$

$$C_{PV_peak} = (i_{0_pv} * \alpha_{pv} + c_{clean}) * P_{Peak}$$

$$C_{PV_b} = b_{pv} * (c_{op} + c_{ins} + \alpha_{pv} * c_{fix_pv})$$

$$C_{else} = c_{fix_elec}$$

$$C_{stor} = i_{0_stor} * \alpha_{Sp} * SoC_{max}$$

Optimization Variables:

P_{Peak} PV Peak Capacity

e_{grid} Electricity from the grid

$e_{pv2load}$ Electricity from PV to load

$e_{pv2grid}$ Electricity from PV to grid

b_{pv} Binary variable, existence PV

SoC_{max} Maximum storage capacity

SoC State of charge

e_{in} Electricity into storage

e_{out} Electricity out of storage

2. Model and Method (3/4)

Optimization: Maximization of self-consumption rate

$$SC_{max} = GC_{min} = \min \sum_{t=0}^{t=35040} e_{grid}(t)$$

Multi-Objective Optimization

$$MO_{min} = \min \left[\alpha * \frac{EC_{min}}{Result_{ECmin}} + (1 - \alpha) * \frac{SC_{max}}{Result_{SCmax}} \right]$$

α

$Result_{ECmin}$

$Result_{SCmax}$

Weighting of opposing objective functions

Result of annual cost minimization

Result of self-consumption maximization

2. Model and Method (4/4)

Constraints:

Load coverage:

$$load(t) == e_{grid}(t) + e_{pv2load}(t) + e_{out}(t)$$

Electricity from PV-system:

$$E_{pv}(t) == e_{pv2load}(t) + e_{pv2grid}(t) + e_{in}(t)$$

Storage's state of charge:

$$SoC(t) == SoC(t-1) - \frac{e_{out}(t)}{\eta_{St}} + e_{in} * \eta_{St}$$

Restrictions:

$$0 \leq P_{peak} \leq P_{peak,max}$$

$$0 \leq SoC(t) \leq SoC_{max}$$

$$SoC(1) == SoC(N) == 0$$

Non-negativity conditions of optimization variables

3. Results (1/7)

Optimization conducted for individual apartments' load profiles

Comparison for AT and DE → DE high retail electricity price because of high renewable surcharge (EEG-Umlage)!

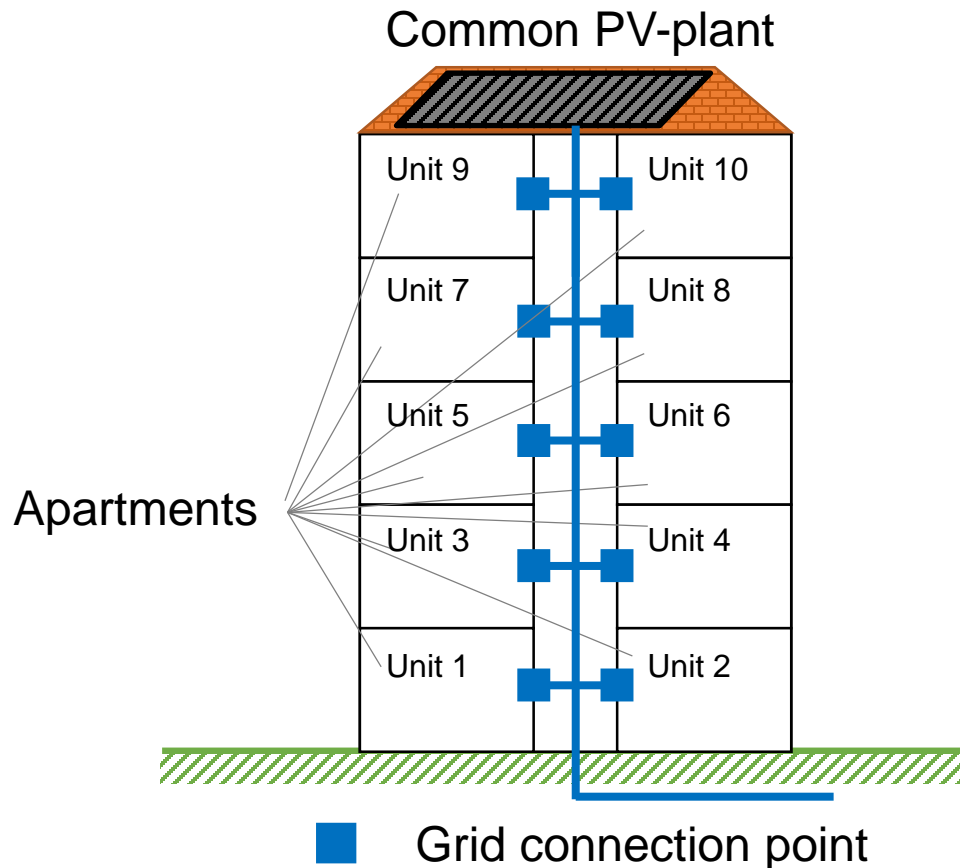

Assumptions:

- 10 apartments (Units 1 – 10)
- Load increasing with number of apartment
→ Unit 1: 1399 kWh/a
→ ...
→ Unit 10: 3683 kWh/a
- Limited rooftop-area
 $P_{peak,max} \leq 21\text{kWp}$

3. Results (2/7)

Austrian retail electricity price

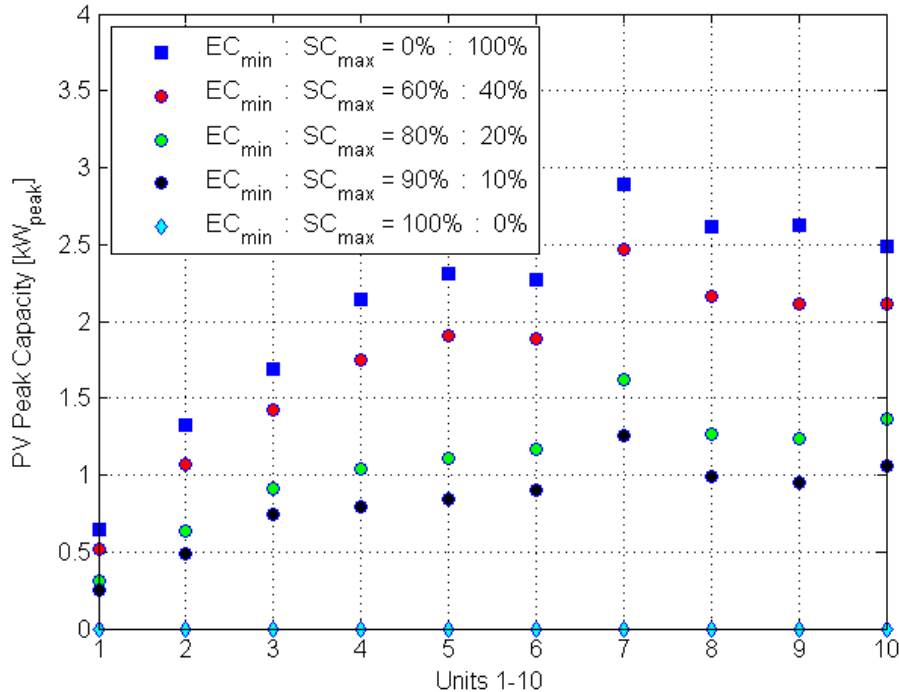

German retail electricity price

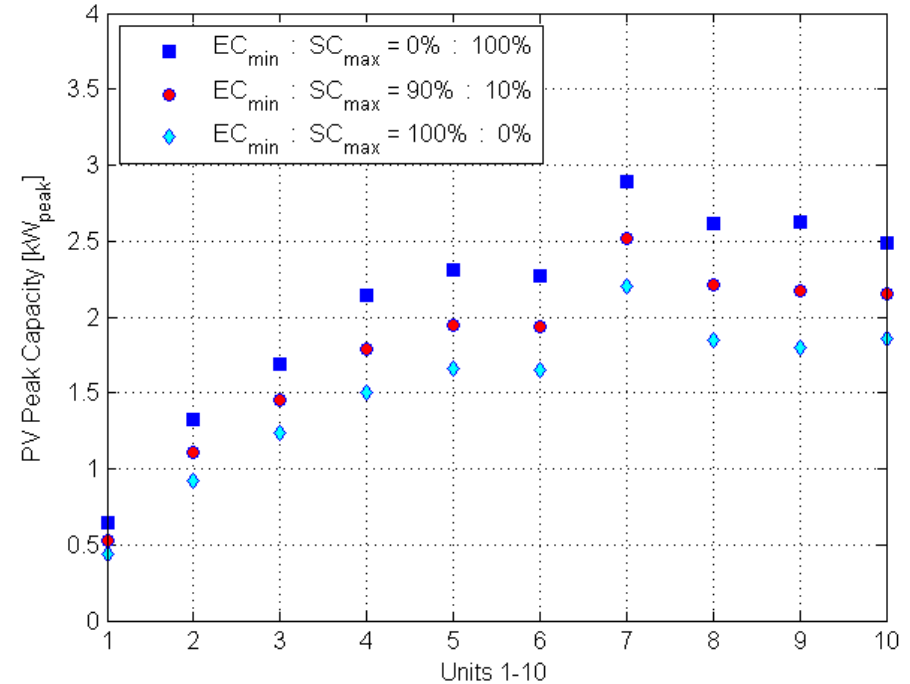

Optimal PV Peak Capacity installed:

- AT: Weight of 100% cost minimization → no PV system built → no cost saving potential
- DE: PV system built in any case → highly profitable

3. Results (3/7)

Austrian retail electricity price

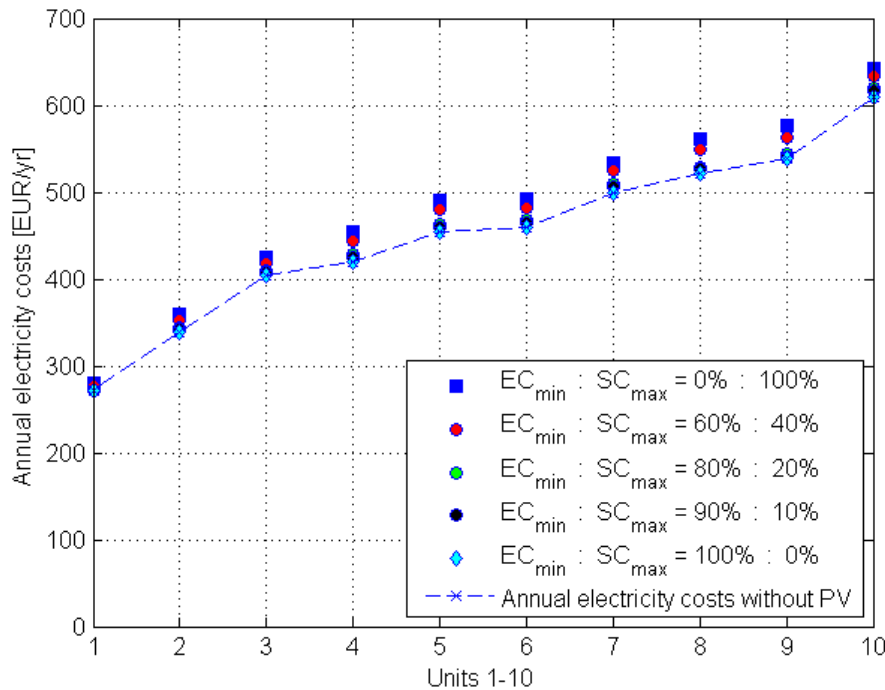

German retail electricity price

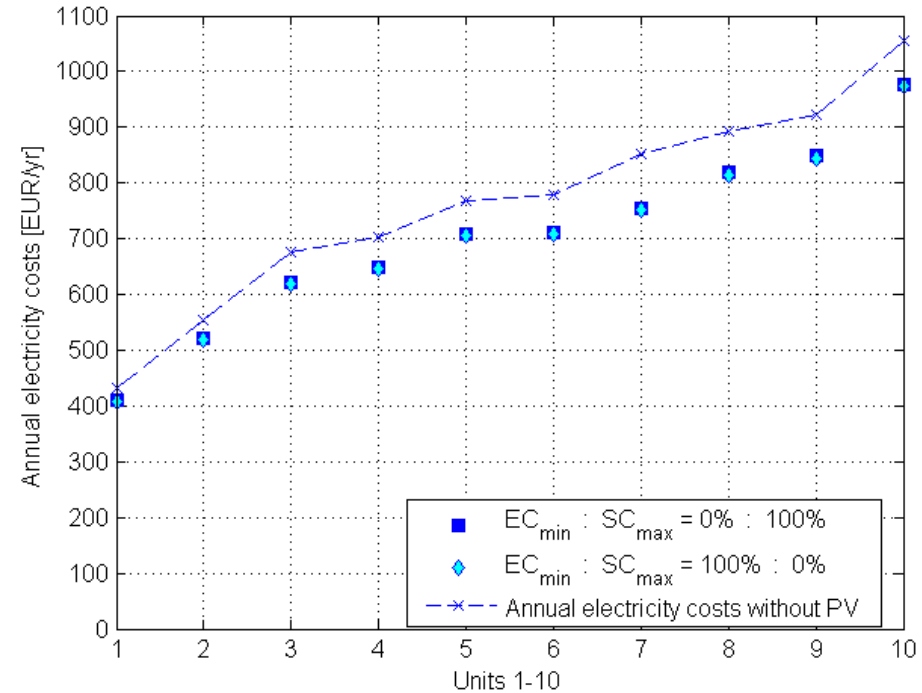

Annual costs of electricity:

- AT: Low variable component of retail electricity price → no profitability
- DE: High variable component of retail electricity price → profitability

3. Results (4/7)

Optimization conducted for building considered as total load

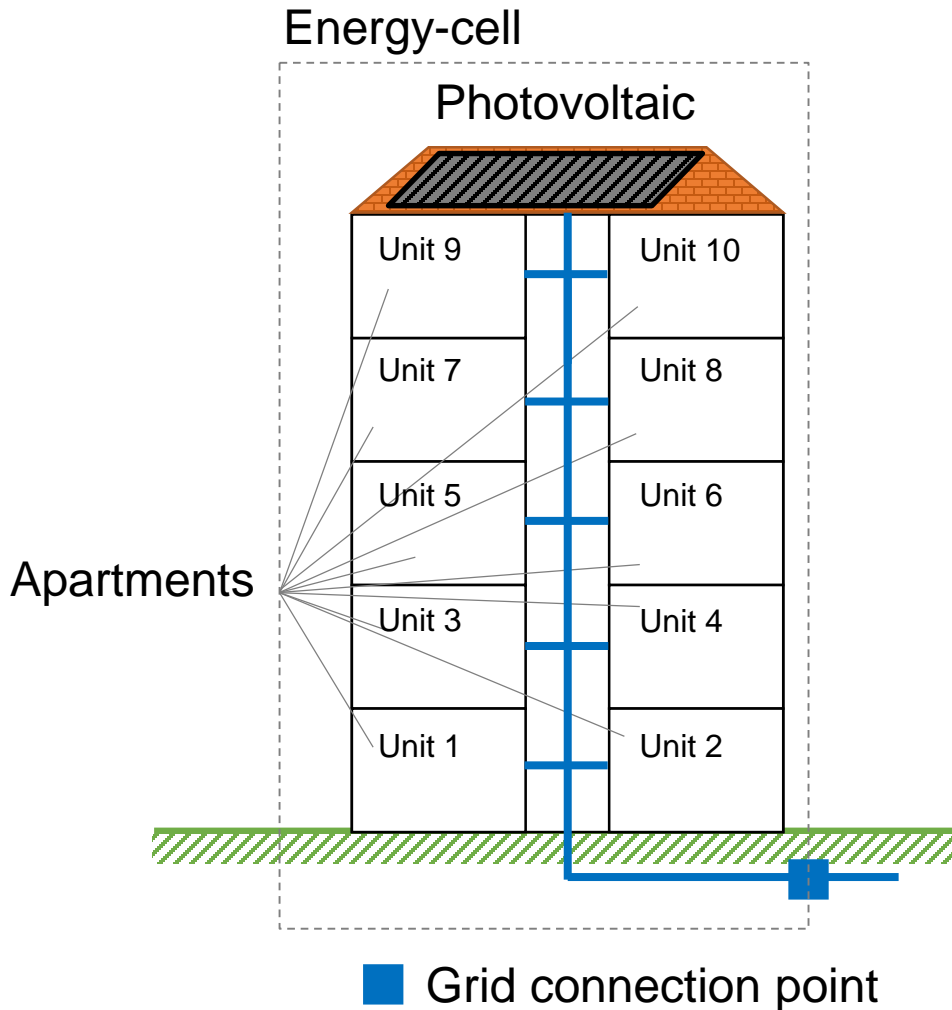

- Optimizations conducted for the building considered as total load
 \neq
 Optimizations conducted for individual load profiles
- Synergy effects between individual load profiles

3. Results (5/7)

Austrian retail electricity price

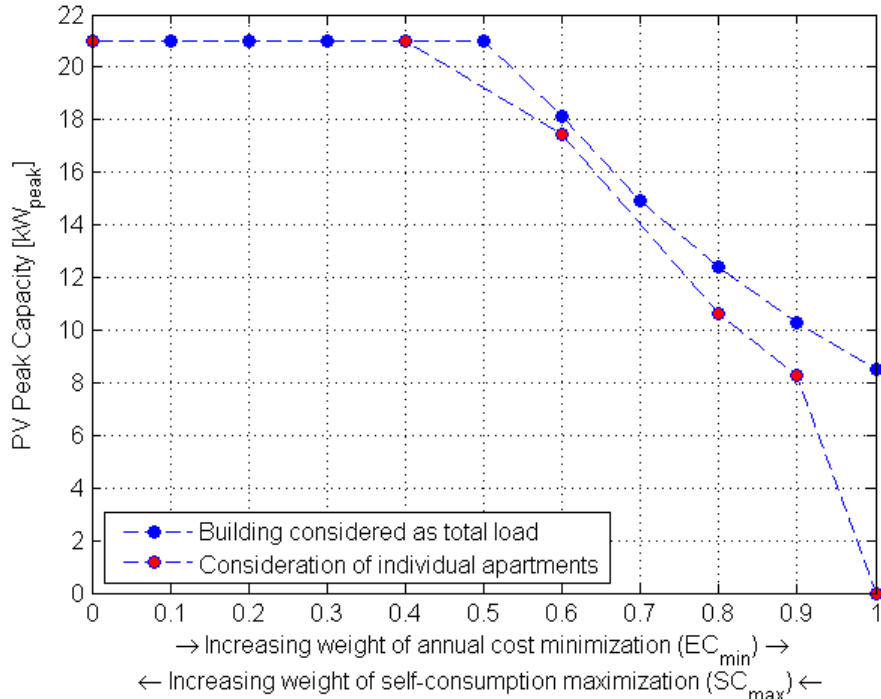

German retail electricity price

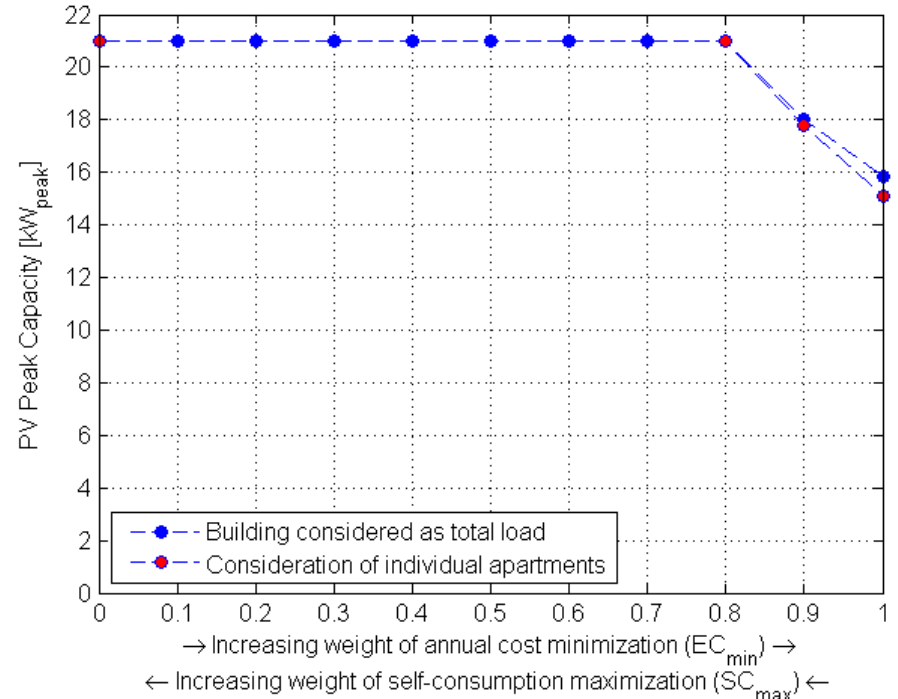

Total load vs. individual apartments:

- Synergy effects between load profiles of individual apartments
- Building as total load → Larger optimal PV system size
→ Increased cost-saving potential

3. Results (6/7)

Building considered as total load: PV system + energy storage

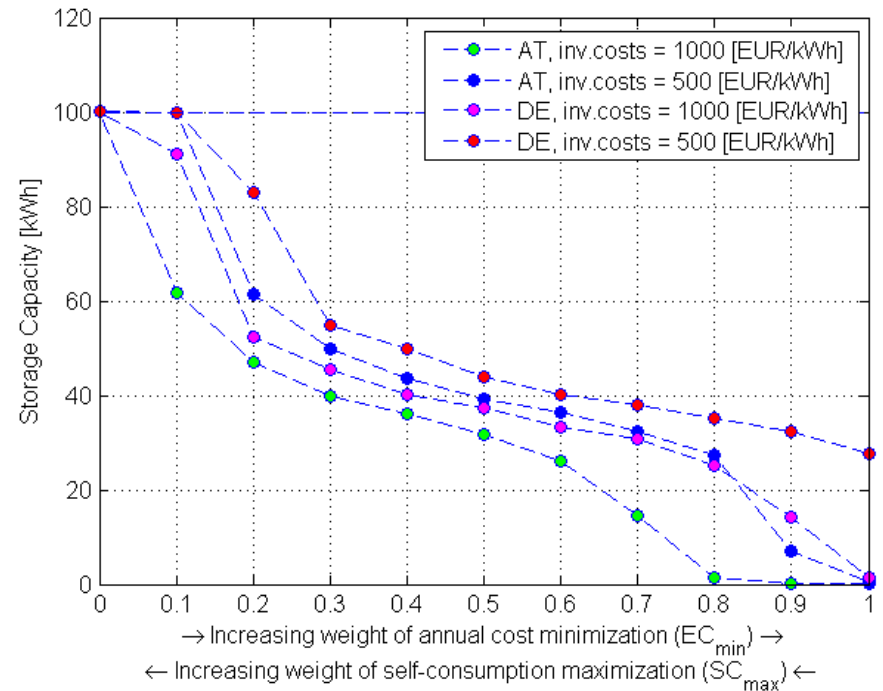
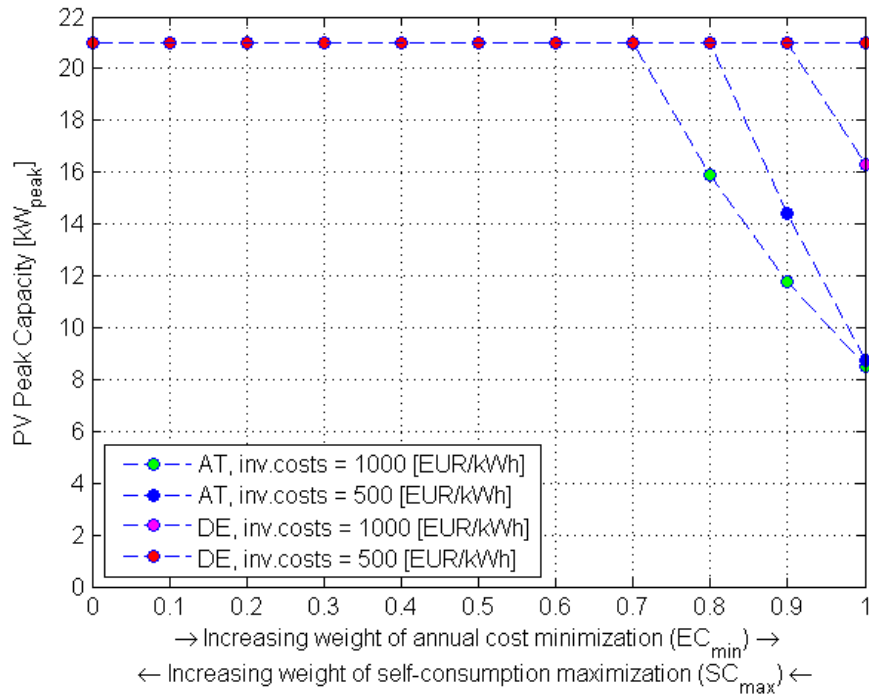

PV Peak Capacity and Storage Capacity:

- The higher the cost saving potential + the lower the storage's investment costs → the larger the PV system and the storage are dimensioned.

3. Results (7/7)

Austrian retail electricity price

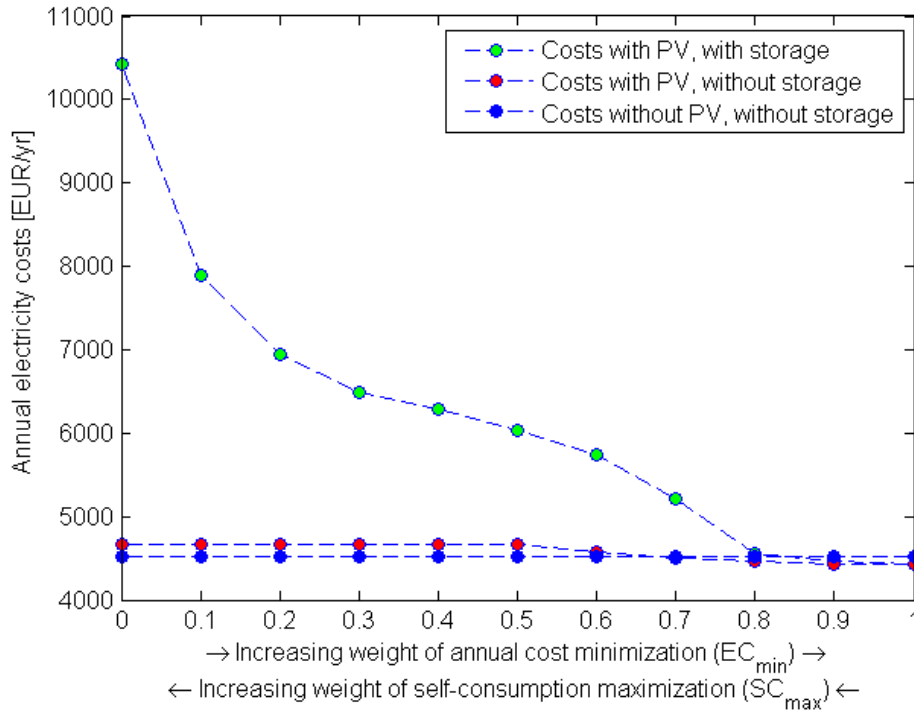

German retail electricity price

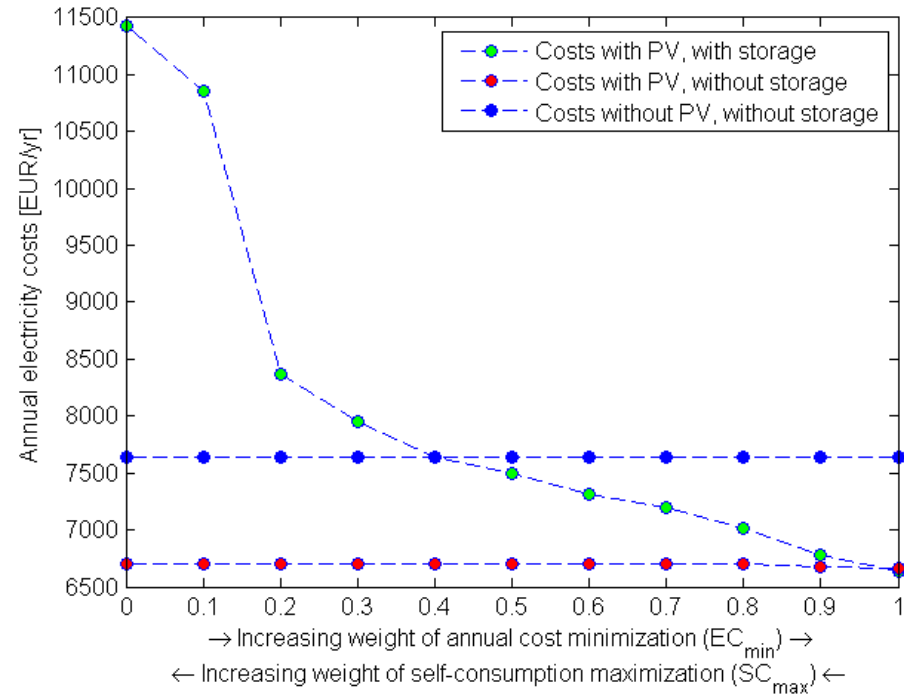

Annual electricity costs comparison:

- AT: → Small cost saving potential with PV
 → No cost saving potential with PV+storage
- DE: → Immense cost saving potential with PV
 → High cost saving potential also with PV+storage

4. Business Models for Austria

Static allocation of PV electricity: (referring to individual load profiles)

PV electricity: Proportionate/Static allocation
Synergies: Not taken into account

Electricity consumption limited by the proportionately allocated amount

Dynamic allocation of PV electricity: (referring to building as total load)

PV electricity: Dynamic allocation
Synergies: Taken into account

Electricity consumption not limited by some allocation schemes
→ higher cost saving potential

5. Conclusions

- Profitability of shared PV systems' usage is right on the border in Austria
- Therefore immediate implementation of the business model with dynamic allocation of PV electricity necessary
- Development of further business models for cross-property trading and integration of electric vehicle charging stations
- For increasing profitability:
 - Further decrease of PVs' specific investment costs
 - Further decrease of storages' specific investment costs
 - Augmentation of variable component of retail electricity price



TECHNISCHE
UNIVERSITÄT
WIEN

Vienna University of Technology

Dipl.-Ing. Bernadette Fina

Technische Universität Wien
Institut für Energiesysteme und Elektrische Antriebe
Energy Economics Group (EEG)

Gußhausstraße 25-29 / E370-3
1040 Wien, Österreich

[E] fina@eeg.tuwien.ac.at

[W] www.eeg.tuwien.ac.at